

# Winter Warm Small Insert

## Homeowner's Installation and Operating Manual

For Use in North America

**SAFETY NOTICE: IF THIS APPLIANCE IS NOT PROPERLY INSTALLED, OPERATED AND MAINTAINED, A HOUSE FIRE MAY RESULT. TO REDUCE THE RISK OF FIRE, FOLLOW THE INSTALLATION INSTRUCTIONS. FAILURE TO FOLLOW INSTRUCTIONS MAY RESULT IN PROPERTY DAMAGE, BODILY INJURY OR EVEN DEATH. CONTACT LOCAL BUILDING OFFICIALS ABOUT RESTRICTIONS AND INSTALLATION INSPECTION REQUIREMENTS IN YOUR AREA.**

**NATIONAL FIREPLACE INSTITUTE**  
**NFI**  
**CERTIFIED**  
[www.nficertified.org](http://www.nficertified.org)

We recommend that our woodburning hearth products be installed and serviced by professionals who are certified in the U.S. by the National Fireplace Institute® (NFI) as NFI Woodburning Specialists or who are certified in Canada by Wood Energy Technical Training (WETT).

**Wood Energy Technical Training**  
[www.wettinc.ca](http://www.wettinc.ca)

**Do Not Discard This Manual: Retain for Future Use**

# Introduction

Thank you for purchasing a Vermont Castings WinterWarm Small Insert, an efficient fireplace carefully engineered to bring you the latest in wood combustion principles and modern foundry technology.

While it can be used to transform a traditional masonry fireplace into a powerful heater, it is also designed to be installed into a listed factory-built fireplace where no masonry fireplace and chimney exists.

Whichever installation you have chosen, you can count on years of comfortable heating and pleasurable fire-viewing if you operate and maintain it according to the directions in this Owner's Guide.

The WinterWarm Small Insert has been tested and listed by Inchcape Testing Services / Warnock Hersey Inc. of Middleton, Wisconsin according to ANSI/UL 1482 for the United States and ULC S628 for Canada. The WinterWarm Small Insert is listed to, and in compliance with, the standards set forth by the Federal Environmental Protection Agency, 40 CFR Part 60.532(b), as stated on the permanent label attached to each appliance.

This manual describes the installation and operation of the WinterWarm Small Insert catalytic-equipped wood heater. This heater meets the U.S. Environmental Protection Agency's emission limits for wood heaters sold after July 1, 1990. Under specific test conditions this heater has been shown to deliver heat at a rate ranging from 8,700 to 31,000 Btu/Hr.

For more complete details on WinterWarm Small Insert performance and specifications, please refer to Page 3.

The WinterWarm Small Insert is designed, tested and listed for burning wood. Do not burn other fuels.

We recommend that you hire a professional installer to install your WinterWarm Small Insert, or to advise you on the installation should you attempt to install it yourself.

Please read the sections of this manual which apply to your installation before you install and use your WinterWarm Small Insert.

Failure to follow these instructions may result in property damage, bodily injury or even death.

## Save These Instructions for Future Reference

### Table of Contents

Specifications .....	3
Installation .....	4
Operation.....	9
Maintenance .....	14
Catalytic Combustor Appendix .....	20
Replacement Parts .....	21

**Proposition 65 Warning:** Fuels used in gas, wood-burning or oil fired appliances, and the products of combustion of such fuels, contain chemicals known to the State of California to cause cancer, birth defects and other reproductive harm.  
California Health & Safety Code Sec. 25249.6

**The WinterWarm Small Insert is designed, tested and listed for burning wood. Do not burn other fuels.**

**The WinterWarm Small Insert is not listed for mobile home installations.**

**Failure to follow these instructions may result in property damage, bodily injury or even death.**

### WARNING

**This fireplace has not been tested with an unvented gas log set. To reduce the risk of fire or injury, do not install an unvented gas log set into this fireplace.**

# Specifications

## WinterWarm Small Insert

EPA Emissions Rating .....gph, catalytic 2.1\*  
 Range of heat output\* ..... 8,700 - 31,100 Btu/hr  
 Maximum heat output\*\* ..... 30,000 Btu/hr  
 Area heated\*\*\* ..... 1,000 sq. ft.  
 Size of wood splits ..... 18" (460mm)  
 Fuel Capacity ..... 30lbs. (13.5kg)  
 Loading ..... Front  
 Flue size ..... 6" (150mm)  
 Fireplace Insert weight ..... 285lbs. (130kg)  
 Primary Air Control ..... Manual/thermostatic  
 Secondary Air Control ..... Self-regulating  
 Glass panel ..... High-temperature ceramic  
 Flue exit position ..... Top

Blower rating ..... 110cfm. (115V, 60Hz)

\*Under specific test conditions used during EPA emissions standard testing.

\*\*This value can vary depending on how the unit is operated, and the type and moisture content of the fuel used. Figure shown is based on maximum fuel consumption obtained under laboratory conditions and on average efficiencies.

\*\*\*These values are based on operation in building-code conforming homes under typical winter climate conditions in New England. If your home is of nonstandard construction (e.g. unusually well insulated, not insulated, built under ground, etc.) or if you live in a more severe or more temperate climate, these figures may not apply. Since so many variables affect performance, consult your Vermont Castings' Authorized Dealer to determine realistic expectations for your home.

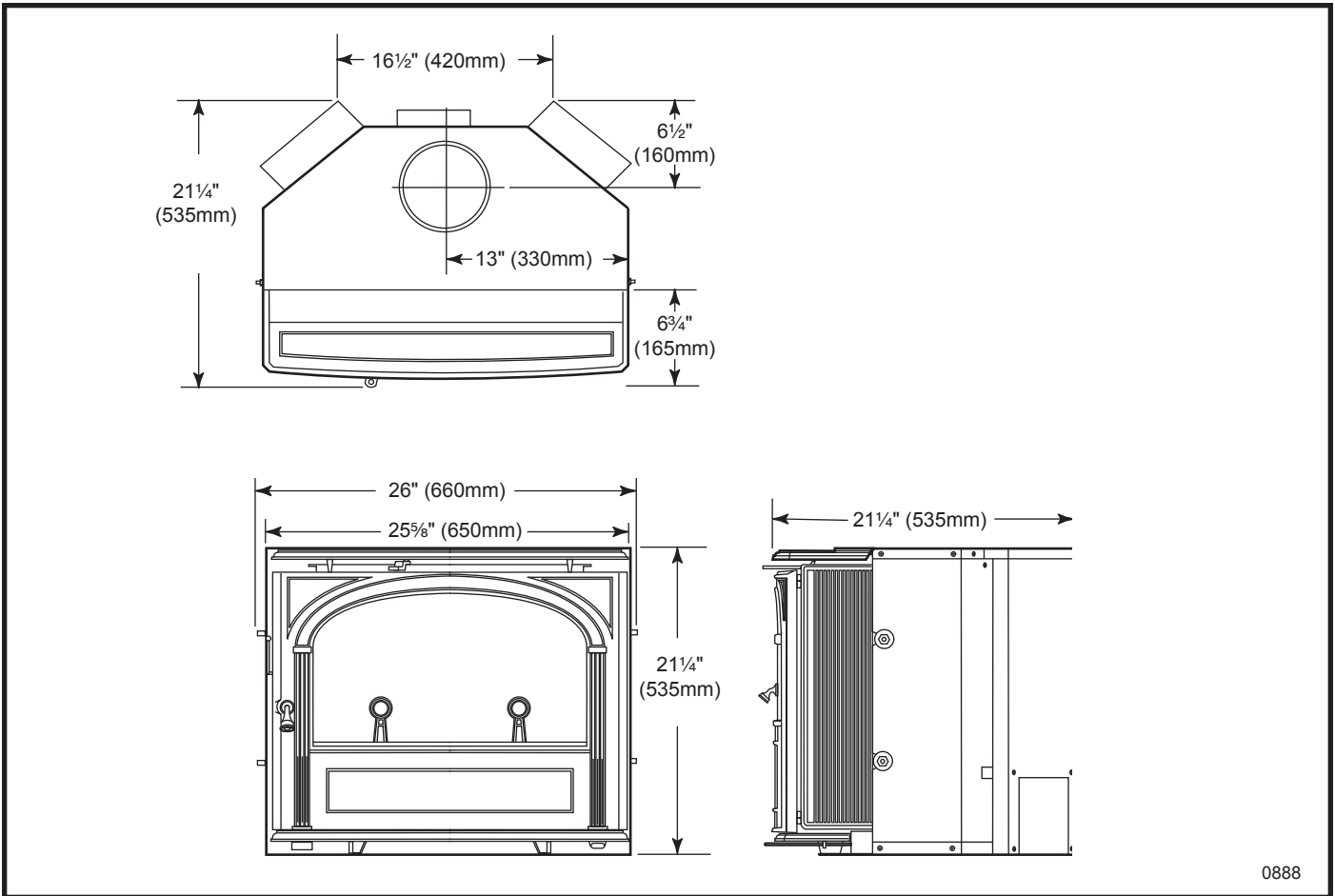

0888

Fig. 1 WinterWarm Small Insert dimensions.

# Installation

Installing the WinterWarm Small Insert into an existing masonry or factory-built fireplace is an effective way to add an efficient heater to your home. The existing fireplace and chimney must meet certain requirements.

## Requirements for Existing Fireplaces

The WinterWarm Small Insert is listed for installation within a properly built masonry or heat circulating, masonry-type fireplace that is constructed in accordance with the requirements of recognized building codes. A heat-circulating masonry-type fireplace must conform to building code standards for masonry fireplaces, and must consist of a factory-built metal firebox with air circulation pathways that are surrounded by masonry materials. Air circulation pathways must not be blocked by the insert or surround panels.

The fireplace and chimney must be clean and structurally sound. Have them inspected by a qualified professional chimney sweep, a mason, or your Vermont Castings' Authorized Dealer before the WinterWarm Small Insert is installed. Any deterioration (cracks, loose mortar or loose bricks) must be repaired.

Codes may permit removal of the damper in order to make a positive connection for the vent between the firebox and the chimney. However, the fireplace should not be modified in any way without first checking with your local building inspector or fire marshal. Provision should be made to restore the fireplace to its original condition if the insert is removed. Do not remove bricks or mortar that may jeopardize the compliance of the fireplace with local building codes.

The WinterWarm Small Insert is also listed for installation in tested and listed factory-built fireplaces. Listings for factory-built fireplaces include meeting standards for both the firebox and chimney. Review the owner's manual, and inspect the fireplace for metal tags or labels which give information concerning installation of inserts into the factory-built fireplace. Codes may permit removal of the damper in order to install a chimney liner. Codes may also permit removal of external trim pieces which do not affect the operation of the unit, as long as the pieces are stored on or within the fireplace for re-assembly if the insert is removed. Air flow within and around the fireplace shall not be altered (louvers or cooling air inlet or outlet ports may not be blocked). Louvered surrounds are permitted. Again, check with local authorities before making any modifications.

## Requirements for Existing Chimneys

Chimney requirements differ for the U.S. and Canada. Specifications for each are listed below. Connect the insert to the chimney in accordance with local codes and the requirements of the listing agency as specified in this manual.

## Chimney Height / U.S. and Canada

Chimney height should be no less than 15' (4.5m) above the hearth and no more than 35' (10.5m).

The chimney should extend at least 3' (914mm) above the highest point where it passes through a roof, and at least 2' (610mm) higher than any portion of a building within 10' (3m). (Fig. 2)

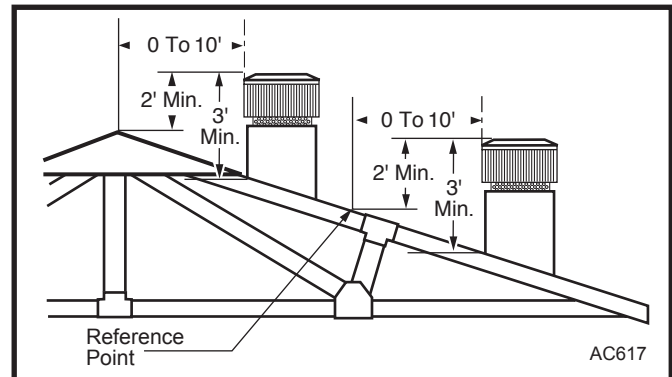

Fig. 2 The 2'-3'-10' rule for chimneys.

**Do not connect your WinterWarm small insert to a chimney flue serving another appliance.**

## U.S.

**In the U.S. (ANSI/NFPA 211, 1988), when installed in a masonry fireplace:**

- A connector must extend from the flue collar to the flue liner.
- The cross sectional area of the flue must be less than or equal to three times the area of the flue collar. If larger, the chimney must be re-lined.
- Means must be provided to prevent room air passing to the chimney cavity.
- Provision must be made for removal of the insert to clean the chimney flue.

**When the insert is installed in a factory-built fire-place:**

- The factory-built chimney must meet type HT requirements of UL 103, ULC S629M or UL 127-1988, or be re-lined from the insert to the chimney top.

**General Considerations / U.S.**

- While not required in most jurisdictions in the U.S., CFM Corporation strongly recommends a full stainless steel chimney liner be installed from the insert to the chimney top to increase overall performance and reduce yearly maintenance.
- A masonry chimney must be well-constructed and must meet minimum code requirements. The chimney flue should have a code-approved liner made of masonry or pre-cast refractory tiles, straight or flexible stainless steel pipe, or a poured-in-place liner. An unlined chimney must be relined professionally.
- The chimney must have a nominal flue size of 6" (150mm) diameter, but no greater than 3 times larger. A chimney larger than this must be re-lined.

Be aware that a chimney originally designed for fireplace use may perform differently when used to vent an air-controlled appliance such as your WinterWarm Small Insert - even if the flue is less than 3 times larger than the flue collar. For example, a chimney on an outside wall may not heat up enough to sustain an adequate draft. Such a flue can often be improved if it is relined to reduce its size and/or insulated to keep it warmer.

- A positive flue connection must be made between the Insert and the first masonry tile or prefabricated metal chimney section. A positive flue connection consists of a plate that seals or replaces the fireplace damper and a section of chimney connector that passes through the plate into the chimney. The chimney connector must be a minimum equivalent to a 6" (150 mm) diameter opening and must be 24 gauge or heavier stainless steel.

Chimney Connection systems are available from a variety of manufacturers. Your Vermont Castings dealer can recommend a system that will best meet the requirements of your particular installation.

**Sealing Requirements / U.S.**

- The chimney must be sealed off from room air, either by a plate at the damper level or by sealing the fireplace opening.

- Unused openings to the flue must be sealed with masonry to the thickness of the chimney wall. Openings sealed with pie plates or wallpaper are a hazard. In the event of a chimney fire, flames and smoke may be forced from the openings.

**Canada**

**In Canada (CAN/CSA-B365-M91, Section 5), whether installed in a m or factory built fireplace:**

- A full chimney liner meeting ULC S635, Class III (stainless steel) must be installed from the insert to the chimney top, and securely attached to both. The damper may be removed to accommodate the liner.
- The opening of the fireplace around the insert must be sealed to prevent room air passing to the fireplace cavity.
- Existing air-circulation chambers in a fireplace with a steel liner may not be blocked.
- Provision must be made for removal of the insert to clean the chimney flue.
- A permanent metal warning label must be affixed to the back of the fireplace stating the fireplace may have been altered to accommodate the insert, and may be unsafe to use as a conventional fireplace. (A Fireplace Modification Tag is included in the hardware bag inside the WinterWarm Small Insert.)

**Minimum Fireplace Dimensions**

The WinterWarm Small Insert will fit most masonry and factory-built fireplaces. To confirm that it will fit yours, measure the lintel depth, plus the height, width, and depth of your fireplace and hearth. Compare them to the measurements in the accompanying chart. If you choose to install a new hearth over an existing fireplace hearth, be sure to take its thickness into consideration when measuring both front and back height of the fireplace.

The unit can be installed virtually flush with the fireplace opening or it can extend up to 6¾" (172mm) onto the hearth. Figure 3 gives minimum and maximum dimensions for fireplaces which will accommodate the WinterWarm Small Insert.

**NOTE:** The clearance between the WinterWarm Small Insert and the mantel, top trim and side trim cannot be reduced by installing shields.

Another requirement to consider is the clearance for movable items such as tables, bookcases, rugs, furnishings, and your woodbox. All combustible materials of this type should be a minimum of 48" (1220mm) from the front surface of the WinterWarm Small Insert. Be sure that family members are aware of this requirement as well, so they too will keep objects a safe distance from the WinterWarm Small Insert.

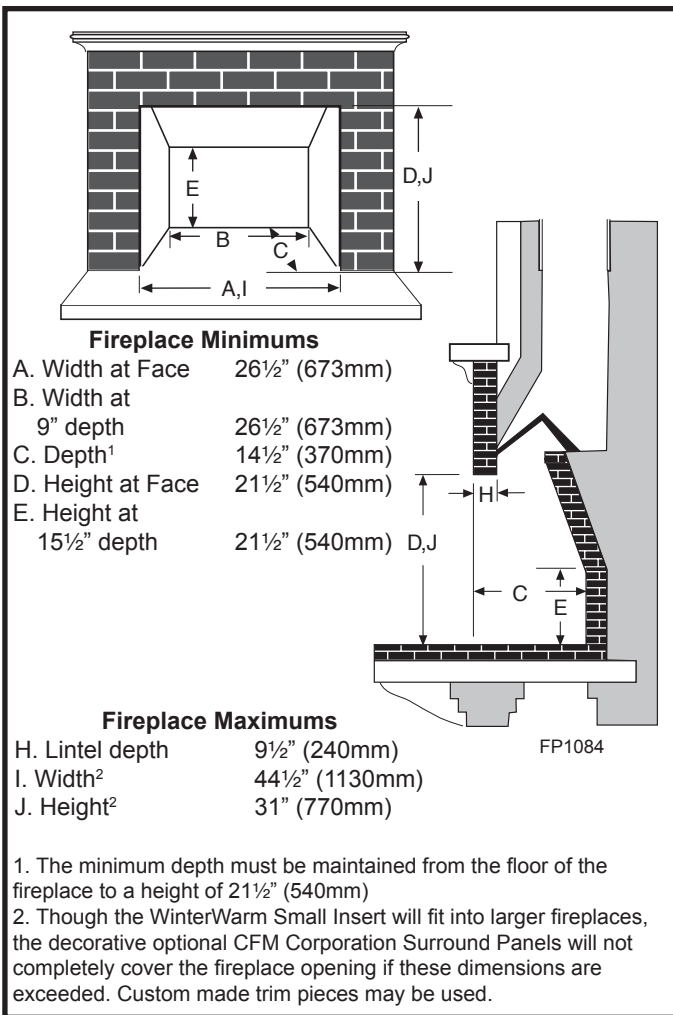

**Fig. 3** Use these measurements to confirm that the WinterWarm Small Insert will fit into your masonry fireplace.

### Clearance Requirements

After confirming that your fireplace is the right size, check the clearance to combustibles. First mark with tape the exact center of your fireplace opening on the hearth. Measure the side clearance from this point. Measure the top trim and/or mantel clearances from the finished hearth surface. Measure the front clearance (to furnishings, etc.) from the fireplace face. (Fig. 4)

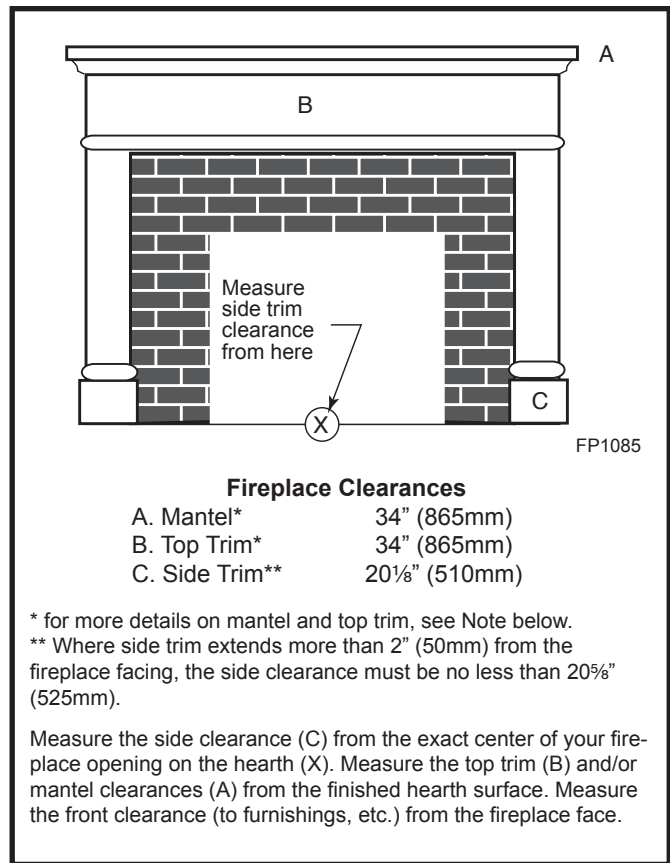
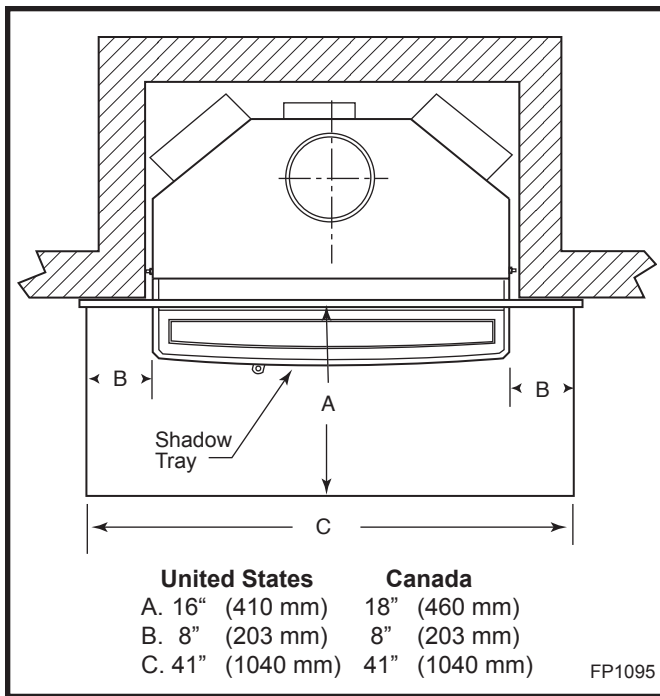

**Fig. 4** Observe these clearances to combustible trim.

### Hearth Requirements

In some fireplaces, the hearth in front of the fireplace opening is brick, stone, slate, or some other non-combustible material that is in direct contact with concrete poured over earth. These are the only hearths that are considered noncombustible. In other fireplaces, the brick or concrete hearth in front of the fireplace opening is supported by heavy wooden framing. Because neither brick nor concrete has good insulating properties, heat radiated by the fire will pass downward through the hearth to the wooden framing. Such hearths are considered combustible.

Unless the fireplace and hearth are constructed over a completely non-combustible surface (such as unpainted concrete over dirt), a floor protector must be used in front of and to the sides of the door as protection against spilled coals and embers. Floor protectors must extend at least 8" (203mm) from the side of the door opening, making the protector 41" (1041mm) wide. In addition, the floor protector must extend from the front door opening a minimum of 16" (406mm) in the United States and 18" (457mm) in Canada. (Fig. 5)



**Fig. 5** Unless your fireplace and hearth are constructed over a dirt floor (or unpainted concrete over dirt), you must use a floor protector that satisfies the above requirements.

The approved construction of a floor protector calls for a minimum of 24 gauge galvanized sheet metal or equivalent such as 7/16" Durock® or Wonderboard® or other listed floor protector. The floor protector may be covered with a noncombustible decorative material if desired.

Custom-made floor protectors may be used if they offer the same protection as the approved floor protector described in the preceding paragraph. Durock® or Wonderboard® have a standard K value of 0.84. Custom-built floor protectors must have a K value equal to, or less than 0.84, meaning that heat will transfer at the same rate or more slowly than the tested standard.

To calculate the thickness required for an alternate material to result in a K value of 0.84, first determine the alternate material's K factor. This information should be available from your local building supply yard. Then, use the following formula to calculate the value:

$$\frac{\text{(K factor of alternate material)}}{(0.84)} \times (7/16" [11\text{mm}]) = \text{(Required thickness of alternate material)}$$

Let's use brick as an example, since it is a commonly used hearth material. Its K factor is 5.0.

$$\frac{(5.0)}{(0.84)} \times (7/16" [11\text{mm}]) = 2.6" (65\text{mm})$$

That is, when using brick for the hearth extension, the brick must be a minimum of 2.6" (65mm) thick. Once you know the K factor of a given material, you can use this same formula to calculate its required thickness for approved hearth protection.

The WinterWarm Small Insert has two leveling screws at the front to accommodate hearth irregularities.

### Optional Surround Packages

Custom-made surround panels may be made from any noncombustible material.

CFM Corporation offers both steel and cast iron Surround panel kits, each in two sizes.

#### Enclosure Area

#### Steel Surround Trim Kits:

- 6", #2970 ..... 36½" x 27" (927 x 686 mm)
- 10", #2971 ..... 44½" x 31" (1130 x 787 mm)

#### Cast Iron Surround Trim Kits:

- 7", #2972 ..... 40" x 28½" (1016 x 724 mm)
- 10", #2973 ..... 45" x 31" (1143 x 787 mm)

### Installing the WinterWarm Small Insert

The hardware bag included with your WinterWarm contains the Draw-down assembly components that provide a means to secure the chimney connector to the Insert. Be sure you have the following items:

- 1, 1/4-20 x 6¾" Threaded Rod (A)
- 2, 1/4" Washers (B)
- 2, Hex Head Nuts (C)
- 1, 1/4-20 x 2" Hook (D)
- 1, 1" x 6" Steel Bar (E)
- 1, 1/4-20 Wing Nut (F)

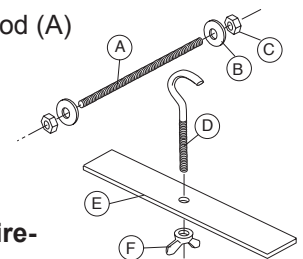

#### 1. Remove or Disable the Fireplace Damper.

If codes allow, remove the damper. Many dampers can be removed simply by removing a cotter pin and/or a set screw.

If it is not permissible or possible to remove the damper, secure the damper in the fully open position.

#### ~ NOTE: CANADIAN INSTALLATIONS ~

**In accordance with CAN/CSA B365-M91, you must permanently secure the Fireplace Modification Tag to the rear of the fireplace cavity if you have modified the fireplace in any way to accommodate installation of a fireplace insert.** This tag is in the hardware bag included with your Insert.

#### 2. Install the Chimney Connector System.

Be sure any chimney connector or adapter is properly installed and secured in place.

**3. Install the Chimney Connector Starter Pipe. (Not supplied)**

- Mark and drill two 5/16", (8mm) holes 1 5/8" (41mm) from the lower edge of the pipe. Locate the holes on an axis that will be perpendicular to the fireplace opening when the pipe is installed. (Fig. 6)

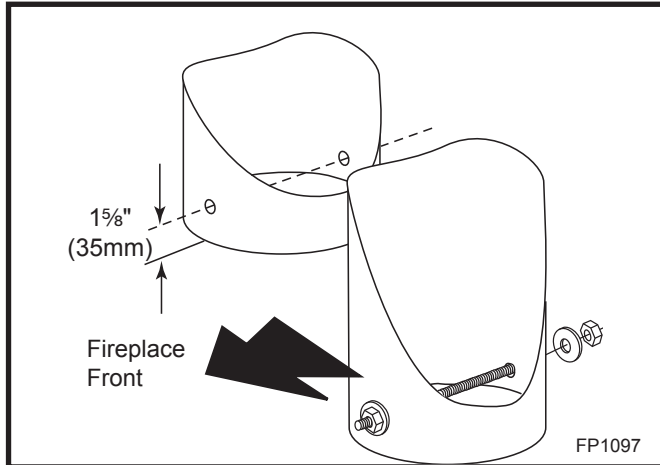

**Fig. 8** Install the threaded rod inside the Starter Pipe (not a supplied item, starter pipe is available from the Chimney Connector manufacturer).

- Install the threaded rod (A), into the starter pipe using washers and hex nuts (B,C), on the outside of the pipe. Tighten the nuts, but do not distort the pipe opening. (Fig. 6)
- Secure the starter pipe to the chimney connector. (Fig. 7)

**4. Install the Floor Protector.** Make sure the floor protector satisfies the requirements discussed on Page 6.

**5. Install the Optional Outside Air Adapter.** Follow the instructions provided with the kit.

**6. Install the Optional Surround Kit.** Follow the instructions provided with the kit.

**7. Slide the Firebox into Position.** At least two people will be needed to move the firebox. Position the firebox so the flue collar lines up with the connector. Use the leveling screws at the front of the Insert to adjust the level. Route the power cord to the side nearest the power supply and test the fans.

**8. Join the Chimney Connector to the Flue Collar.**

- Assemble the draw-down hook and bar (D,E,F).
- From inside the firebox, reach up through the flue collar and engage the hook over the threaded rod inside the starter pipe. Position the steel bar behind the two tabs within the flue collar and then turn the wing nut clockwise to draw the starter pipe down. (Fig. 7)

**9. Connect the Blower power cord to the power supply.**

This completes installation of your WinterWarm Small Insert.

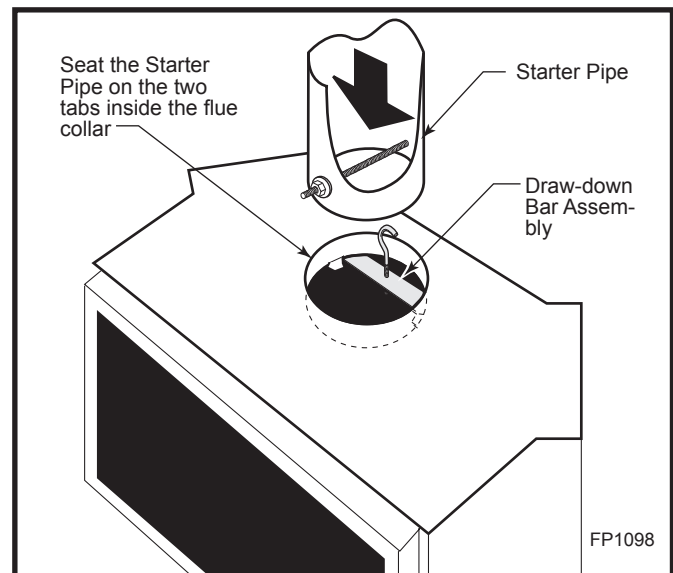

**Fig. 7** Attach starter pipe to flue collar.

# Operation

## Your WinterWarm Insert's Controls and What They Do

All WinterWarm Small Insert controls are conveniently located on the front. (Fig. 8)

Three controls regulate the performance of your WinterWarm Small Insert:

The **primary air control** supplies oxygen for the fire.

The **damper** directs air flow within the fireplace.

The variable-speed **fan control**, or rheostat, regulates the warm air flow into the room.

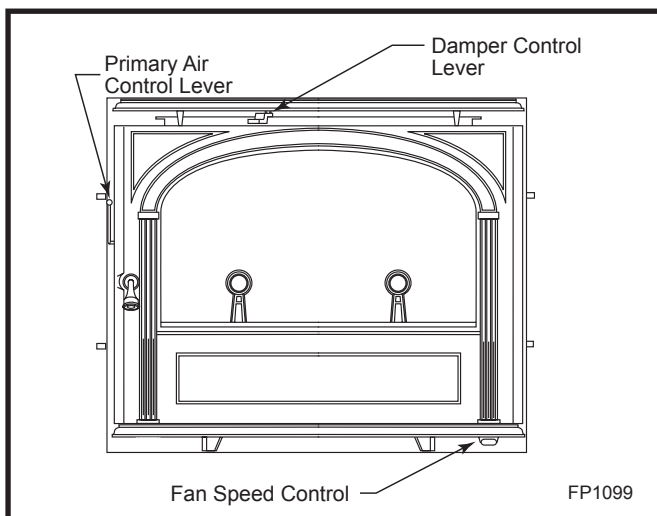

Fig. 8 WinterWarm Small Insert controls.

## Primary Air Control

A single air control regulates the amount of heat the fire will produce and how long it will burn.

The **primary air control lever** is located midway up the left side panel. The lever regulates air for starting, maintaining, and reviving the fire.

Generally, more air entering the stove makes the fire burn hotter and faster, while less air prolongs the burn.

The WinterWarm Small Insert's air supply is increased when the control lever is moved counterclockwise, and decreased when moved clockwise. It may be set anywhere between the two extremes, however, depending on the amount of heat desired. (Fig. 9)

To complement the manual setting of the air control, the WinterWarm Small Insert has an internal automatic thermostat that ensures an even delivery of heat at the manual setting you select.

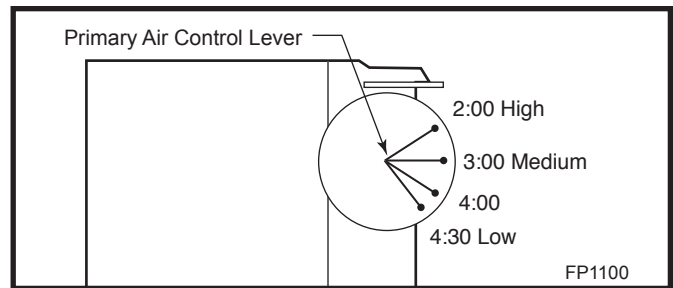

Fig. 9 Settings for the primary air control range from 2:00 (high burn rate) to 4:30 (low burn rate).

## The Damper

The **damper** directs air flow within the fireplace. The damper is operated by moving the lever located above the door. It has two positions: Open, to start or revive the fire; and closed, for normal operation. The damper is open when the lever is to the far right, and closed when to the far left. There are no intermediate settings for damper position. (Fig. 12)

To open the damper, insert the fall-away handle into the hole in the lever, lift up on the lever and move it to the far right.

To close the damper, move the lever to the left, continuing past the resistance to lock the damper in position.

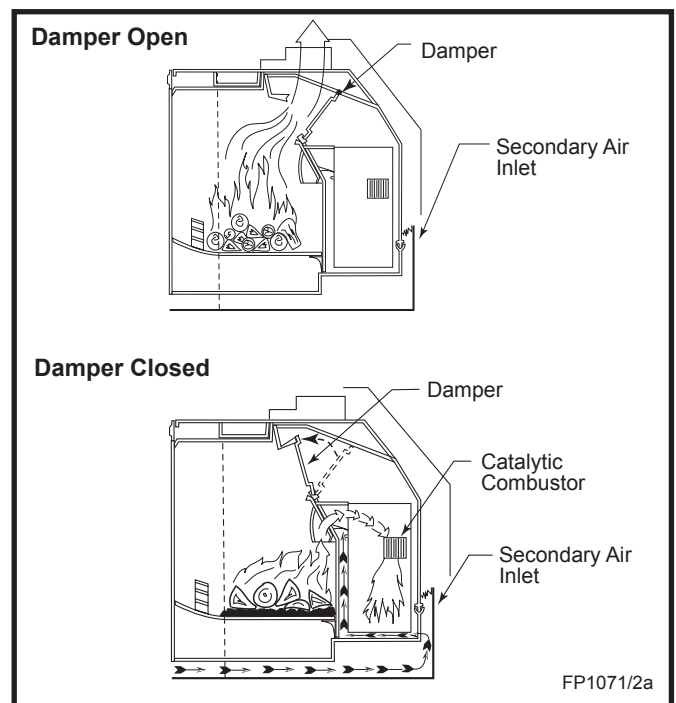

Fig. 10 When the damper is open, smoke is vented directly to the chimney. When the damper is closed, smoke is channelled through the catalytic combustor.

## The Fans

Two fans deliver a steady stream of warm air into the room. Use the fall-away handle, (used to operate the damper), to control fan settings. (Fig. 11)

The fan speed should be set at “low” when operating at low to medium burn rates. The fan speed may be set anywhere between “low” and “high” when operating at high burn rates.

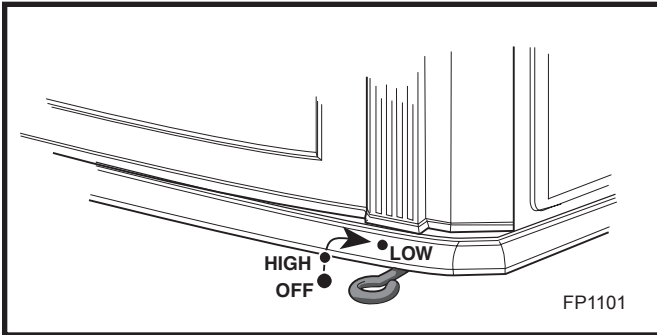

Fig. 11 Fan speed control settings.

## Burn Only High-Quality Wood

The WinterWarm Small Insert is designed to burn natural wood only; do not burn fuels other than that for which it was designed.

You'll enjoy the best results when burning wood that has been adequately air-dried. Avoid burning “green” wood that has not been properly seasoned or cordwood that is more than two years old.

The best hardwood fuels include oak, maple, beech, ash, and hickory that has been split, stacked, and air-dried outside under cover for at least one to two years.

For areas that do not have a supply of hardwood, commonly burned softwoods include tamarack, yellow pine, white pine, Eastern red cedar, fir, and redwood. These too should be properly dried.

Your WinterWarm Small Insert will accept wood up to 18” (460mm). Longer wood pieces work better than short ones.

Wood should be stored under cover to maintain dryness. Even for short-term storage, however, keep wood a safe distance from the heater and keep it out of the areas around the heater used for re-fueling and ash removal.

## Use the Air Control Settings that Work Best for You

No single air control setting will fit every situation. Each installation will differ depending on the quality of the fuel, the amount of heat desired, and how long you wish the fire to burn.

The control setting also depends on your particular installation’s “draft,” or the force that moves air from the stove up through the chimney. Draft is affected by such things as the length, type, and location of the chimney, local geography, nearby obstructions, and other factors.

Too much draft may cause excessive temperatures in the WinterWarm Small Insert, and could even damage the combustor. On the other hand, too little draft can cause backpuffing into the room and/or the “plugging” of the chimney or combustor.

How do you know if your draft is excessively high or low? Symptoms of too much draft include an uncontrollable burn or glowing-red cast iron. A sign of inadequate draft is smoke leaking into the room through the stove or chimney connector joints, low heat, and dirty glass.

In some newer homes that are well-insulated and weather-tight, poor draft may result from insufficient air in the house. In such instances, an open window near the stove on the windward side of the house will provide the fresh air needed.

Another option for getting more combustion air to the stove is to duct air directly from the outside to the stove. In fact, in some areas provisions for outside combustion air are required in all new construction. To duct outside air to your WinterWarm Small Insert, use Outside Air Kit #3252 available from your Vermont Castings dealer. Follow the installation instructions included with the kit.

When first using the stove, keep track of the settings of the air controls. You will quickly find that a specific setting will give you a fixed amount of heat. It may take a week or two to determine the amount of heat and the length of burn you should expect from various settings.

Most installations do not require a large amount of combustion air, especially if adequate draft is available. **Do not for any reason attempt to increase the firing of your heater by altering the air control adjustment range outlined in these directions.**

Use the following primary air control lever and fan speed control lever settings as a starting point to help determine the best settings for your installation.

### WinterWarm Small Insert Control Settings

Primary Air		Air Circulation	
Burn Rate	Control Setting	Fan Speed	Control Position
High	2:00	High	Horizontal
Medium	3:00 - 4:00	Low	Turn clockwise
Low	4:30	Off	Turn Counterclockwise

## How To Build and Sustain a Wood Fire

A WinterWarm Small Insert leaves the factory with the combustor installed.

In the United States, it is against the law to operate this wood heater in a manner inconsistent with operating instructions in this manual, or if the catalytic combustor is deactivated or removed.

## High-Efficiency Wood Burning with Catalytic Combustion

The components of the catalytic combustion system in your WinterWarm Small Insert work together to produce optimum conditions for secondary combustion.

When the damper is closed, smoke is directed through the **catalytic element**, which causes ignition of smoke at temperatures of 450°-550°F (230°-290°C), half the temperature normally required for unaided secondary combustion.

The catalytic element is a ceramic “honeycomb” coated with the catalytic material. The element is located in the **secondary combustion chamber**, molded from a special **high-temperature insulating refractory** material. The design of the chamber provides the correct environment necessary for secondary combustion of the fuel (smoke).

Catalytic combustion is activated by closing the damper, thereby exposing the smoke to the combustor.

Closing the stove damper may also reduce the draft, so to avoid putting out the fire or deactivating the combustor, close the damper only when a fire is well-established. When starting a fire, wait until the fire is well established and there is an ember bed of at least 3-4” (76 - 102mm) before closing the damper.

Never kindle a fire with colored paper or paper that has colored ink or a glossy surface, and never burn treated wood, garbage, solvents, or trash. All of these may poison the catalyst and prevent it from operating properly. Never burn cardboard or loose paper except for kindling purposes. Never burn coal; doing so can produce soot or large flakes of char or fly ash that can coat the combustor and cause smoke to spill into the room. Coal smoke also can poison the catalyst so that it won't operate properly.

In general, the fire must be sufficiently well-established to ensure that catalytic activity is initiated. When first starting a fire, a medium- to high- firing rate must be maintained for at least twenty minutes. This ensures the stove, catalyst, and fuel are all stabilized at the proper operating temperatures.

Even though it is possible for the fire to get quite hot within a few minutes after a fire is started, the combustor

may stop working or the fire may go out if the fire is allowed to die down immediately as a result of the damper being closed. Once the combustor starts working, heat generated by burning the smoke will keep it working.

To determine whether the combustor is operating, compare the amount of smoke leaving the chimney when the damper is open and when it is closed. This procedure is described on Page 17.

## Starting and Maintaining a Wood Fire

**Burn solid wood fuel only in the WinterWarm Small Insert, and burn it directly on the grate. Do not elevate the fuel. Do not burn coal or other fuels.**

Cast iron is a superior material for solid fuel stoves but it must be treated with respect. It is extremely strong, but can be broken with a sharp blow from a hammer or from the thermal shock of rapid and extreme temperature changes. It is important to temper the cast iron plates with an initial series of 3-4 break-in fires. The plates expand and contract with changes in temperature. Minimize thermal stress by allowing the plates to adjust gradually during the break-in fires by following Steps 1-3 on the following page.

Always be certain the damper is open when starting a fire or when re-fueling. To open the damper, lift up on the lever and move it to the right. (Fig.12)

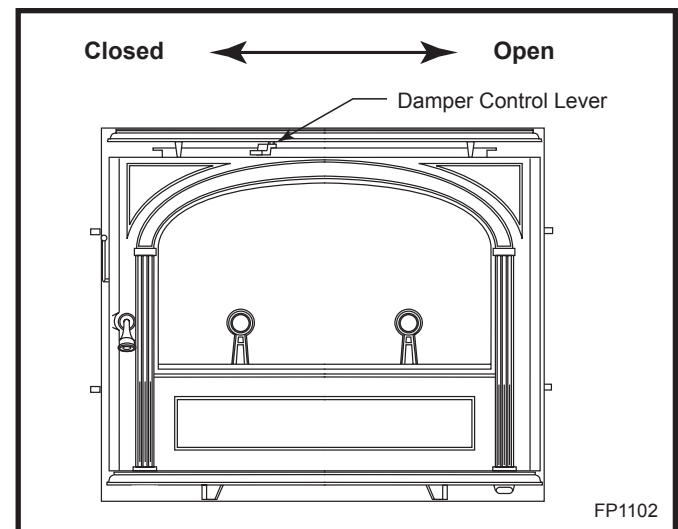

Fig. 12 Damper control.

**WARNING: Operate your WinterWarm Small Insert only with the door fully closed. If the door is left partially open, gas and flame may be drawn out of the fireplace opening, creating risks of both fire and smoke.**

Follow these guidelines as you start and maintain the fire, and remove the ashes.

1. Open the stove damper, and open the primary air control fully.
2. Lay some crumpled newspapers on the bottom grate. Place on the paper six or eight pieces of dry, finely-split kindling. On the kindling lay two or three larger sticks of split dry wood approximately 1-2" (25-50 mm).

**Do not use chemicals or fluids to start the fire. Do not burn garbage or flammable fluids such as gasoline, naphtha, or engine oil.**

Also, never use gasoline-type lantern fuel, kerosene, charcoal lighter fluid, or similar liquids to start or "freshen up" a fire in this heater. Keep all such liquids well away from the heater while it is in use.

3. Light the newspaper and close the door. Gradually build up the fire by adding a few 3-5" (76 -127mm) diameter splits.

If this is your initial break-in fire, let the fire burn brightly, but not to excess. Control the fire's intensity by adjusting the air control lever. After an hour or so stop adding wood so that the fire dies out gradually.

For ongoing operation after the initial break-in, continue to add a few sticks at a time of a progressively larger size. Be sure to keep the fuel load behind the front grate bar at all times. Continue until you have a live ember bed at least 3-4" (76 - 102mm) deep. This may take an hour or longer, particularly when the WinterWarm Small Insert is vented to an exterior masonry chimney or when you are just starting a fire.

You'll soon find that the WinterWarm is **HOT WHILE IN OPERATION! KEEP CHILDREN, CLOTHING, AND FURNITURE AWAY. CONTACT MAY CAUSE SKIN BURNS.**

**NOTE:** Some chimneys need to be "primed," or warmed up, before they will draw sufficiently to start a fire. To correct this situation, roll up a couple pieces of newspaper, place them on top of the kindling and toward the back of the stove, light them, and close the doors. This should heat the chimney enough to initiate a draft.

Once the draft is established, open the front door and light the rest of the fuel from the bottom. Do not light the main bed of fuel until the chimney begins drawing, and repeat the procedure as often as necessary if the initial attempt is unsuccessful.

4. Once a good ember bed of at least 3-4" (76 - 102mm) has formed, close the damper to activate the combustor. To ensure continued operation of the combustor, let the fire burn hot for an additional ten to fifteen minutes after the damper is closed.

5. Close the primary air control to a medium-low setting. The fire volume will diminish immediately, but the WinterWarm Small Insert will continue to heat up. Maintain control of the fire using the primary air control, and remember: reduce the setting for less heat, increase the setting for more heat. Refer back to the air control settings chart on Page 6 for recommended settings at different burn rates.

**Do not over-fire this heater.**

Overfiring may cause a house fire, or can result in permanent damage to the stove and to the catalytic combustor. If an exterior part of the WinterWarm Small Insert glows, you are overfiring.

### Reloading and Reviving a Wood Fire

Open the stove damper, set the air control on "High," and wait at least fifteen seconds for the draft to increase. Open the door slowly.

Check the ash level, and empty the ash pan if necessary. Replace the pan.

Add the fuel, smaller pieces first. If it is necessary to use wood smaller than the 18" (460mm) optimum size, be sure to fill the firebox as completely as possible by loading the wood pieces alternately on the left and right. Split wood will fill the firebox more completely and reduce the frequency of reloading.

If you have an ember bed of at least 3-4" (76 - 102mm), leave the damper open and the thermostat set on "high" for 10-15 minutes, then close the damper. If the ember bed is less than 3-4" (76 - 102mm), you may have to let it burn longer.

Finally, adjust the air control and fan speed for your desired heat level.

**NOTE:** If the charcoal bed is relatively thick and your fuel is well-seasoned, it is possible to add fresh fuel (smaller pieces first), close the door and damper, and reset the air control immediately.

### Special Tactics for Cold-Climate Heating

The WinterWarm Small Insert is capable of producing up to 30,000 Btu/hour and heating an area of up to 1,000 sq. ft. However, many factors affect heating performance and can influence the extent to which the WinterWarm Small Insert can heat a given area.

A well-insulated home, located in a moderate climate and with the WinterWarm Small Insert located centrally in an open floor plan, will be easier to heat than a drafty home in the far north in which a WinterWarm Small Insert is installed on an exterior wall at the end of a long house.

In Fireplace Insert installations, over-sized chimneys can produce less effective results than those that are properly sized, and interior chimneys usually perform better than those located outside the house.

Different results may be experienced even in the same installation if you switch from burning good, dry wood to wood that is partially rotted or inadequately seasoned.

To compensate for these factors in cold climates, it may be necessary to operate the WinterWarm Small Insert for longer periods of time than described above before closing the damper, or to leave the air control set to a higher level more of the time.

### Remove and Store Ash Safely

Check the ash pan before reloading the stove, and empty if necessary using the following procedure:

- Turn off the fans.
- Open the damper.
- Open the load door.
- Pull open the ash chamber door with the fall-away handle. (Fig. 13)
- If the ash level is nearing the top, take the pan outdoors and empty the ash into your ash container.
- Ash may contain hot coals and must be treated with extreme care.
- Before replacing the ash pan, clear away any ash that has spilled over the sides and back of the pan.
- Replace the ash pan and close the ash door and front door.

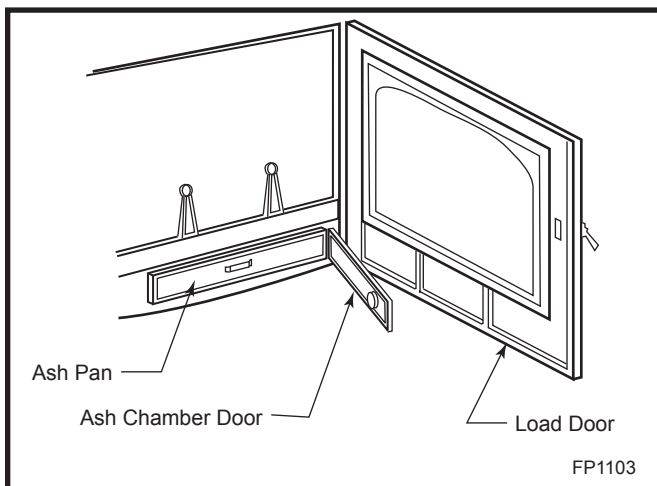

**Fig. 13** Wear heavy stove gloves if it is necessary to handle the ash when hot coals are present.

Empty the ash pan regularly, typically every one to three days. The frequency will vary depending on how you operate your WinterWarm Small Insert; more wood is consumed at higher heat output settings, and ash will accumulate faster.

Ash should be removed frequently and placed outdoors in a metal container with a tight-fitting lid. The closed container of ash should be placed on a non-combustible floor or on the ground, well away from all combustible materials, pending final disposal. If the ash is disposed of by burial in soil or otherwise locally dispersed, it should be retained in the closed container until all cinders have thoroughly cooled. Wood ash may be used as a garden fertilizer.

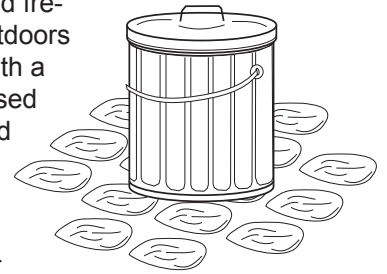

**CAUTION:** Never use your household or shop vacuum cleaner to remove ash from the fireplace; always remove and dispose of the ash properly.

## Maintenance

### Keep Your WinterWarm Small Insert Looking New and Working Its Best

#### Care of the Cast Iron Surface

An occasional dusting with a dry rag will keep the painted cast iron of your WinterWarm Small Insert looking new.

If the paint needs retouching, first allow the surface to cool completely. Mask glass, trim parts and enamelled areas. Wire-brush those areas needing to be painted. Touch-up with high temperature stove paint available from your local dealer. Apply the paint sparingly. Two light coats are better than one heavy one.

#### Care of the Porcelain Enamel Surface

Use a soft brush as necessary. Do not use water or other liquids on your WinterWarm Small Insert. Fingerprints usually can be buffed off porcelain enamel with a dry, soft cloth. If marks remain, allow the WinterWarm Small Insert to cool completely, then buff with a slightly damp, soft cloth. Dry completely before starting a fire to avoid streaking.

Never use abrasives or harsh chemical cleaners on the porcelain enamel finish; the enamel may scratch and expose the cast iron, which can then stain or rust. If you must remove spills or stains from porcelain surfaces, make sure the fire is out and the WinterWarm Small Insert has cooled completely before cleaning. Use a kitchen appliance cleaner and/or polish specially formulated for enamel surfaces. Apply the cleaner sparingly with a soft cloth, and buff away all traces.

#### Cleaning the Glass

The WinterWarm Small Insert glass system requires a minimum amount of cleaning. Most carbon deposits that accumulate will burn off during hot fires.

Ash residue that accumulates on the glass should be removed periodically to prevent etching. To clean the glass, use the following procedure.

- Be sure the glass is completely cool.
- Cleaning with water will work in most cases. Use a glass cleaner especially made for this purpose only if deposits are specially heavy. (If heavy deposits are a frequent occurrence, however, evaluate your operating techniques.) Do not use abrasive cleaners.
- Rinse the glass thoroughly.
- Dry the glass completely.

**NOTE:** The WinterWarm Small Insert glass is coated with a special material on one side that helps reflect heat back into the fire chamber. Do not attempt to remove this coating.

#### Adjust the Door Latch Periodically

The front door of the WinterWarm Small Insert should close securely to prevent accidental opening and should close tightly to prevent air from leaking into the fire chamber. The door handle will be positioned vertically when the door is closed.

Over a period of time, the gasket around the door will compress and the latch may need adjustment. To adjust the handle, follow this procedure:

1. Loosen the small lock nut with a 7/16" wrench. (Fig. 14)
2. Extend the striker screw one turn by turning it with a 1/8" Allen wrench.
3. Re-tighten the lock nut, while at the same time holding the striker screw with the Allen wrench to prevent its turning.

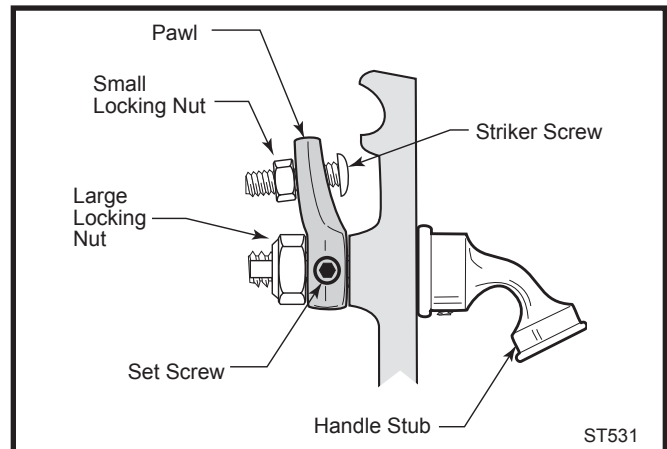

**Fig. 14** Turn the door latch striker screw in or out to tighten or loosen the door latch.

Test the door seal. Close the door on a dollar bill and attempt to pull it free. If the bill is freed with little resistance, the gasket isn't snug enough at that spot. Continue to make small adjustments until the setting is right.

If additional adjusting of the latch does not enable the door to seal sufficiently in one area, try "adjusting" the gasket in that area. Pack more cement or a smaller diameter gasket into the channel beneath the gasket so the main gasket is raised and makes contact with the door frame. If this procedure doesn't solve the problem, replace the gasket. Instructions for gasket replacement are given later in this section.

## Adjust the Damper as Needed

Examine your WinterWarm Small Insert's damper after the first 50 hours of use and adjust it if necessary. Thereafter, check the damper at least once a year and adjust as needed.

To inspect how well the damper seals, first make sure the fire is out and the WinterWarm Small Insert is cool. Open the front door, and close and lock the damper. Inspect how the damper plate seals against the damper frame. (Fig. 15)

There should be no gaps in the gasket and the damper should be tight against the frame. If a section of gasket is missing, replace the gasket. Instructions for gasket replacement are given later in this section. If the gasket appears to be in good condition, continue by pushing gently on the damper. There should be some give but no rattle. If adjustment is necessary, proceed as follows:

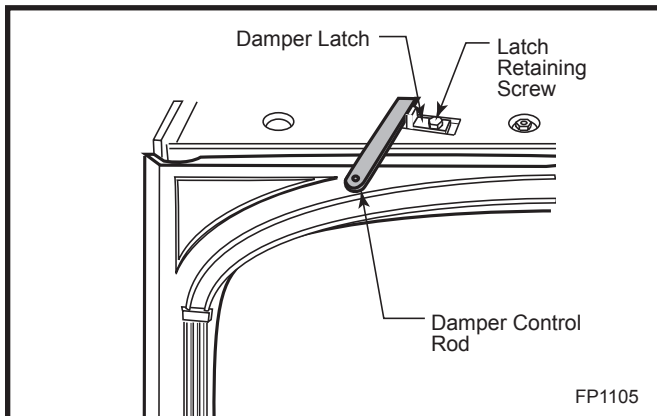

**Fig. 15** With the mantel removed, the damper latch is exposed for adjustment.

1. Remove the Mantel piece.
2. With the Damper Control Lever in the open position (to the right), loosen the retaining screw on the Damper Latch by turning it counterclockwise. (Fig. 15)
3. Move the latch approximately 1/16" to the left, and tighten the screw.
4. Examine the upright tab that holds the damper rod in place. If the screw is loose, tighten it. If the tab is bent, replace it.
5. Close and lock the damper, and check for gap and rattle. Repeat the procedure if necessary.

If the problem is still not solved, replace the damper gasket. Instructions are on Page 16.

## IMPORTANT NOTES

- Do not operate the WinterWarm Small Insert if the glass is damaged or broken.
- The glass used in your WinterWarm Small Insert is coated with a special material on one side that reflects heat back into the fire chamber. To replace new glass correctly, look along the edge of the glass for a printed notice that reads, "THIS SIDE OUT". Be sure to install the glass with the notice side out.
- Replace glass only with CFM Corporation high temperature ceramic glass, available from your Vermont Castings' Authorized Dealer.

## Removing and Replacing Door Glass

Follow this procedure to replace glass.

- Open the door and loosen the four retaining clip screws that hold the glass to the door. Swing the clips out of the way. Tilt the glass away from the door frame and lift up. (Fig. 16) Wear gloves and use caution when handling broken glass.
- Examine the gasket that seals the glass to the door frame. Replace if necessary with gasket obtained from your local Vermont Castings' Authorized Dealer. Directions for replacing gaskets are given below.
- Check the channel at the bottom of the door frame, and clear away debris if necessary.
- Carefully place the new glass in the door frame.
- Secure the clips, being careful not to over-tighten. Be sure the glass is firmly seated against the gasket. Close the door gently to confirm the clips have been properly positioned. It is possible for the glass to be damaged if the clips have been installed incorrectly and the door is closed with force.

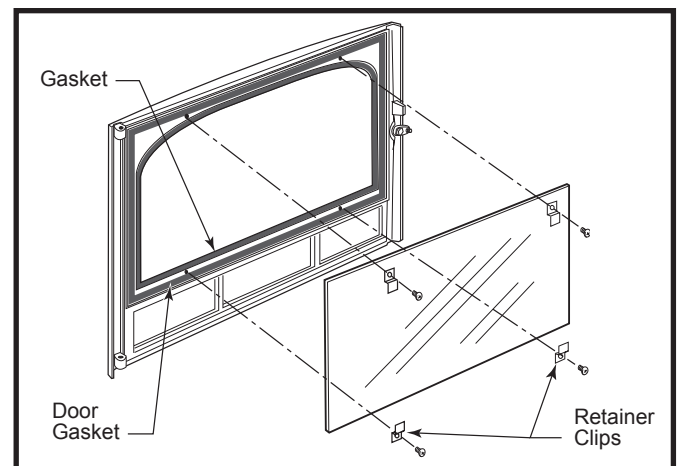

**Fig. 16** Components for the front door may be disassembled to allow replacement of the glass, gaskets or both.

## How to Replace Gaskets

Your WinterWarm Small Insert uses rope-type fiberglass gaskets to make a tight seal between some parts. With use, particularly on those parts that move, gaskets can become brittle and compressed and can begin to lose their effectiveness. These will need periodic replacement.

All of the gaskets used are made of fiberglass. The three sizes of replaceable gasket are listed below, along with their application.

### Replaceable WinterWarm Small Insert Fiberglass Gaskets

Gasket Size .....	And The Parts It Seals
1/2" (1203564).....	Door to the front - 5.6'
5/16" (1203591).....	Glass to the door - 5.2'
5/16" (1203588).....	Ash door to the front - 4'
.....	Bypass damper - 2'
.....	Damper housing - 2.5'
.....	Fireback - 3'
3/16" (1203556).....	Thermostat cover to the left
.....	side - 1'

To change a gasket, wait until the fire is out and the stove has cooled. Wear protective eyewear and a dust mask. The procedure is the same for all gaskets.

1. Remove the existing fiberglass gasket by grasping an end and pulling firmly.
2. Use a wire brush or the tip of a screwdriver to clean the channel of any remaining cement or bits of gasket.
3. Apply a thin bead of stove cement to the newly-cleaned groove.
4. Place a new gasket into the groove. Wait until you have placed all but a couple inches from the end before you trim the end to an exact fit.

## Replacing the Insert's Door Gaskets

- Remove the door by lifting it straight up from its hinge pins.
- Lay it face down on a padded surface.
- Remove the glass. Follow the instructions for removing and replacing glass which start on page 15.
- Replace gaskets. Follow steps 1-4, above.
- Replace the glass.
- Replace the door.

## Replacing the Damper Gasket

- Lift and remove the left and right burn plates.
- Two wedges hold the fireback in place. Using a hammer and a block of wood, tap upward on the wedges and remove them.
- Grasp the fireback by its vertical ribs and remove it, together with the throat hood.
- Disconnect the damper linkage from the damper by removing the hex head bolt from the damper tab.
- Remove the two 1/4-20 screws holding the damper housing to the back. The damper and damper housing may now be removed.
- Replace the damper gasket.

**NOTE:** Check the gaskets on the damper housing and fireback while these components are out of the stove. These gaskets seal non-moving parts and are much less subject to wear than other gaskets, but can be replaced if necessary.

- Reverse the procedure to replace the damper, damper housing and fireback.

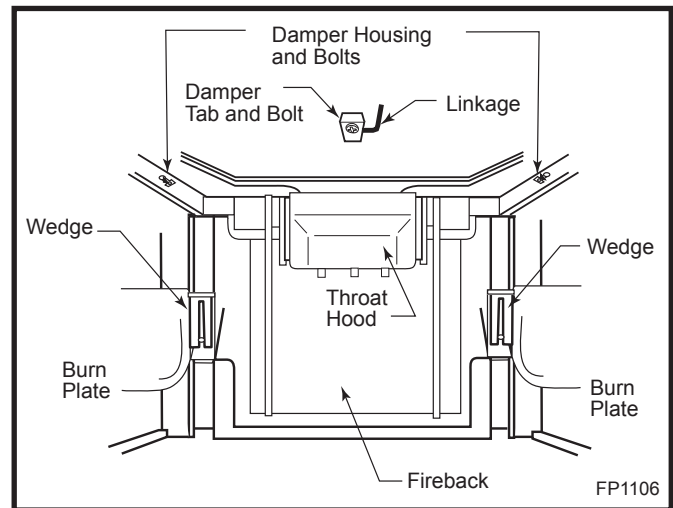

**Fig. 17** Remove the parts illustrated above to access the damper.

## Care of the Catalytic Combustor

Your wood heater contains a catalytic combustor which should be inspected regularly and replaced periodically to ensure proper operation. **It is illegal in the United States to operate this wood heater in a manner inconsistent with operating instructions in this manual, or if the catalytic element is deactivated or removed.**

Under normal operating conditions, the catalytic combustor should remain active for two to six years (depending on the amount of wood burned). However, it is important to monitor the combustor to ensure it is functioning properly, as well as to determine when it needs to be replaced. A non-functioning combustor will result in a loss of heating efficiency, and an increase in creosote and emissions.

The combustor should be visually inspected “in place” for fly ash accumulation and physical damage three times per year. Actual removal of the combustor is not recommended unless a more detailed inspection is warranted because of diminished performance as outlined below.

The refractory package that houses the catalytic combustor should be inspected annually for a build-up of fly ash and cleaned if necessary. This may be done during examination of the catalytic combustor.

## When To Suspect a Combustor Problem

The best way to evaluate the performance of your WinterWarm Small Insert’s combustor is to observe the amount of smoke leaving the chimney — both when the combustor has achieved “light-off” and when it has not. Follow this simple two-step procedure:

- With a fire going and the combustor properly activated with the damper closed to route smoke through it as described in the Operation Section, go outside and observe the smoke leaving the chimney.
- Then, open the stove damper and once again observe the smoke leaving the chimney.

Significantly more smoke should be observed after the second step when the stove damper is open and exhaust is not routed through the combustor. Be careful, however, not to confuse smoke with steam from wet wood.

If this test indicates a problem, consider other possible factors as well, such as the time of year or a change in the quality of your fuel. In spring and fall, draft is weaker than it is in colder winter weather, and fires can burn sluggishly. Small, hot fires are a good solution under these conditions.

Burning “green” (insufficiently seasoned) wood will result in poorer performance than burning properly seasoned fuel. You may have to run your stove hotter (more air) to achieve good performance if you are burning green or wet wood. Also, consider any changes in your operating routine as well.

Once you have ruled out any other possible causes for a decline in performance, you may proceed with an inspection of the combustor.

## Removal and Inspection of the Combustor and Refractory Package

Before you begin, observe the basic safety precautions for working with dusty materials: always wear protective eyewear, a recommended dust mask, and gloves.

1. Remove the andirons and burn plates.
2. Two cast iron wedges hold the fireback in place. Using a block of wood and a hammer, tap the wedges upward. (Page 16, Fig. 17)
3. Grasp the fireback by its vertical ribs and remove it, together with the throat hood.
4. Clean the left and right exhaust pockets of the refractory package. Use a shop vacuum to avoid damaging the fragile refractory material. (Fig. 18)

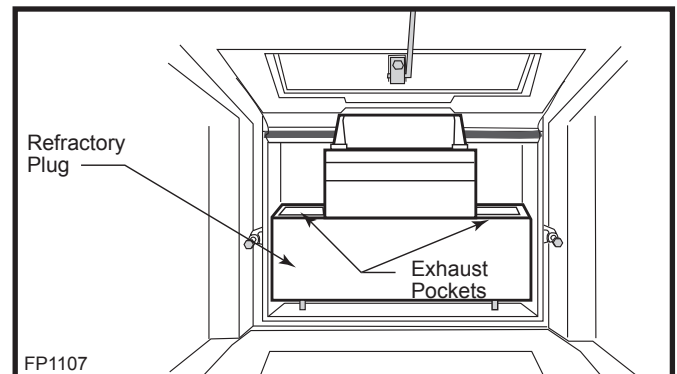

**Fig. 18** The refractory package.

5. Inspect the gaskets that seal the fireback to the damper frame and stove back. Replace if necessary.
6. Carefully remove the refractory plug.
7. Gently slide the catalytic element out of the refractory chamber. Check the element and the bottom of the refractory chamber for a build-up of fly ash.
8. If the honeycomb is clogged, take it outside for cleaning. Blow gently through the honeycomb. A sizeable quantity of ash may be removed from the element.
9. Inspect the element. Although small hairline cracks will not affect performance, the element essentially should be intact. If the element is broken in pieces or has sections missing, it should be replaced. Call your local Vermont Castings Authorized Dealer for a replacement element, item #160-2521.

If replacement of the refractory package is required, proceed to #10.

10. Remove 1/4-20 x 1/2" hex head screw from the damper tab holding the damper link to the damper and let the link drop down.

11. Remove the two (2) 1/4-20 x 1 1/2" hex head screws and washers holding the damper housing to the stove back and drop the damper housing out of the stove.

12. Carefully slide the refractory package out of the unit.

13. Install the new refractory package making sure to pilot a small hole for the secondary probe in the proper location at the back of the refractory package.

14. Reinstall the damper housing and damper link.

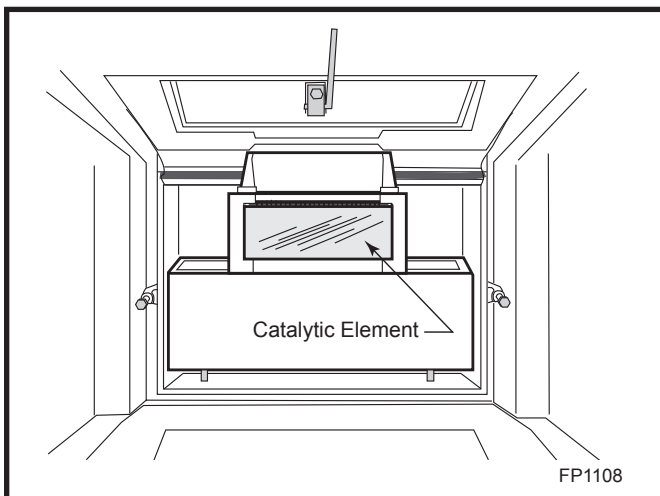

**Fig. 19** The refractory plug is removed to access the catalytic element.

### Watch for Better Results

Operate the stove in a typical manner for two weeks, inspecting the chimney and the chimney connector frequently during this period. If creosote is not building up as fast, it is likely the performance change was caused by fly ash deposits on the catalytic element. However, continue the inspections of the chimney system for a few weeks to ensure that proper performance continues.

If you continue to find a significant creosote build-up or if you continue to see excessive smoke from the chimney, the catalytic element will need to be replaced. Contact your nearest Vermont Castings Authorized Dealer for information about a replacement element.

**NOTE:** Use only the replacement catalyst #160-2521 supplied by CFM Corporation.

**The refractory and the catalytic element are extremely fragile and must be handled carefully.**

## The Chimney System

### A Clean Chimney System is Safer and Works Better

Although the catalytic combustion system in your WinterWarm Small Insert can reduce creosote formation dramatically, it is not a substitute for regular inspection and cleaning of the chimney and chimney connector.

### Learn To Recognize — And Avoid — Creosote

Your WinterWarm Small Insert has been designed to minimize creosote build-up. Regular chimney inspection and maintenance, however, must still be performed. For safety, good stove performance, and to protect your chimney and chimney connector, inspect your chimney and chimney connector on a regular schedule. Clean the system if necessary. Failure to keep the chimney and connector system clean can result in a serious chimney fire.

When wood is burned slowly, it produces tar, organic vapors and moisture which combine to form creosote. The creosote vapors condense in the relatively cool chimney flue of a slow-burning fire. As a result, creosote residue accumulates on the flue lining. When ignited, this creosote makes an extremely hot fire within the flue system that can damage the chimney and overheat adjacent combustible material. If a significant layer of creosote has accumulated — 1/8" (3mm) or more — it should be removed to reduce the risk of a chimney fire.

If you do experience a chimney fire, act promptly to:

- Close the damper and thermostat lever.
- Get everyone out of the house.
- Call the Fire Department from a nearby house.

You should inspect the system every two weeks during the heating season as part of a regular maintenance schedule. To inspect the chimney, let the WinterWarm Small Insert cool completely. Then, using a strong light, sight up through the flue collar into the chimney flue. If it is not possible to inspect the flue system in this fashion, the firechamber must be removed to provide better viewing access.

If it is necessary to remove the firechamber to inspect or clean the chimney, this is how to do it:

- Let the WinterWarm Small Insert cool.
- Disconnect the fan power cord.
- You may wish to lighten the firebox by removing the load door, andirons, grate and ash door.
- Retract the two levelling screws until they bear no weight.

- Disconnect the flue liner or vent connector from the flue collar of the stove.
- Slide the firechamber forward until you have access to the fireplace opening.
- Inspect the flue.

You can now inspect the smoke shelf area and the chimney. Before replacing the WinterWarm Small Insert, this area should be inspected for signs of deterioration and cleaned thoroughly with a chimney brush.

Clean the chimney using a specially designed brush the same size and shape as the flue liner. Flexible fiberglass rods are used to run the brush up and down the liner, causing any deposits to fall to the bottom of the chimney where they can be removed through the clean-out door.

The chimney connector should be cleaned by disconnecting the sections, taking them outside, and removing any deposits with a stiff wire brush.

Reinstall the connector sections after cleaning, being sure to secure the individual sections with sheet metal screws.

If your WinterWarm Small Insert is installed into a factory-built fireplace, the chimney should be cleaned from above using the appropriate size round brush and enough rods to clean the entire length of the flue.

If you can't do the chimney inspection yourself, contact your local Vermont Castings' Authorized Dealer, or engage a professional chimney sweep to perform the inspection and cleaning of the chimney.

Reverse the procedure to re-install the firechamber.

## Fireplace System Maintenance Schedule

### Fireplace:

#### Daily:

- Ash should be removed before the level reaches the top of the pan. Check each time you re-load, or at least once a day.
- Keep the area around the fireplace clear of any combustible material.

#### Yearly Spring Cleaning:

- Remove ash from the firebox and replace with a moisture-absorbing material (such as Kitty Litter) to keep the interior of the fireplace dry.
- Touch up painted surfaces with black paint.

### Flex Connection:

#### Two Weeks:

- Inspect the chimney and flue connection. Clean the system if necessary.

#### Yearly Spring Cleaning:

- Disassemble the flue connection and take it outdoors for inspection and cleaning. Replace weak sections of connector.
- Inspect the chimney for signs of deterioration. Repairs to a masonry chimney should be made by a professional mason. Replace damaged sections of prefabricated chimney. Your local Vermont Castings' dealer or a chimney sweep can help determine when replacement is necessary.
- Thoroughly clean the chimney.

## Appendix: Catalytic Combustor

In any chemical reaction, including the combustion process, there are certain conditions which must be met before the reaction can take place. For example, a reaction may require a certain temperature, or a certain concentration of the reactants (the combustion gases and oxygen), or a certain amount of time. Catalysts, though not changed themselves during the reaction, have the ability to act at a molecular level to change these requirements. In the secondary combustion chamber of the WinterWarm Small Insert, the catalyst reduces the temperature at which secondary combustion can start from the 1000° - 1200°F (540° - 650°C) range to the 500° - 600°F (260° - 315°C) range, increasing efficiency, and reducing creosote and emissions.

The catalytic reaction, though advantageous, does have some limitations of its own. Primary among these is the reactants (the gases) come into close physical contact with the catalyst itself.

To ensure the necessary contact, the catalytic element in your WinterWarm Small Insert is composed of a ceramic base in the shape of a honeycomb. On each of the honeycomb's many surfaces a coating of the catalyst (usually a noble metal such as platinum or palladium) is applied. The large surface area exposed in this configuration ensures that the combustion gases have the greatest opportunity to come in contact with the catalyst.

Loss of catalytic activity will be apparent in several ways. First you may notice an increase in fuel consumption. Second, there will be a visible increase in the rate at which creosote builds up in your chimney connector system. You may also notice a heavy discharge of smoke from the chimney. There are a number of catalytic problems which can cause loss of activity:

### Blockage

While the honeycomb pattern ensures good contact, it also increases the resistance to flow of the combustion gases, and, because of the many surfaces, provides more places for creosote and fly ash to deposit. It is important to follow the operating instructions in order to minimize these deposits, and to periodically inspect your catalyst for signs of blockage.

### Masking and Poisoning

While the catalyst itself does not enter into the combustion process, it is possible for certain elements, such as lead and sulfur, to attach to the active sites on the surface of the honeycomb. Though the catalyst is still there, it is covered, or masked, by the contaminant, and cannot function. To avoid this situation, it is important not to burn anything in your WinterWarm Small Insert that is a source of these contaminants. Particularly avoid painted or treated wood, coal, household trash, colored papers, metal foils, or plastics. Chemical chimney cleaners may also contain harmful elements. The safest approach is to burn only untreated, natural wood.

### Flame Impingement

The catalytic element is not designed for exposure to direct flame. If you continually over-fire your WinterWarm Small Insert the chemistry of the catalyst coating may be altered, inhibiting the combustion process.

Thermal degradation of the ceramic base may also occur, causing the element to disintegrate. Stay within the recommended guidelines of the Operation section.

### Mechanical Damage

If the element is mishandled, damage may occur. Always treat the element carefully. Remember the catalyst is made of a ceramic material; treat it as you would fine china. Hairline cracks will not affect the performance of the catalyst, as long as the steel sleeve holds the element in the proper position.

### Peeling

Peeling of the surface coat may occur if the catalytic element is frequently subjected to excessive temperatures. Follow the operating instructions carefully to avoid this type of damage.

Every CFM Corporation product is equipped with a Corning "Long-Life"® "Honeycomb"®. If for any reason you must ship your catalytic element, remember its fragile nature. Place the element in a plastic bag, and package it with a generous amount of shock absorbing material.

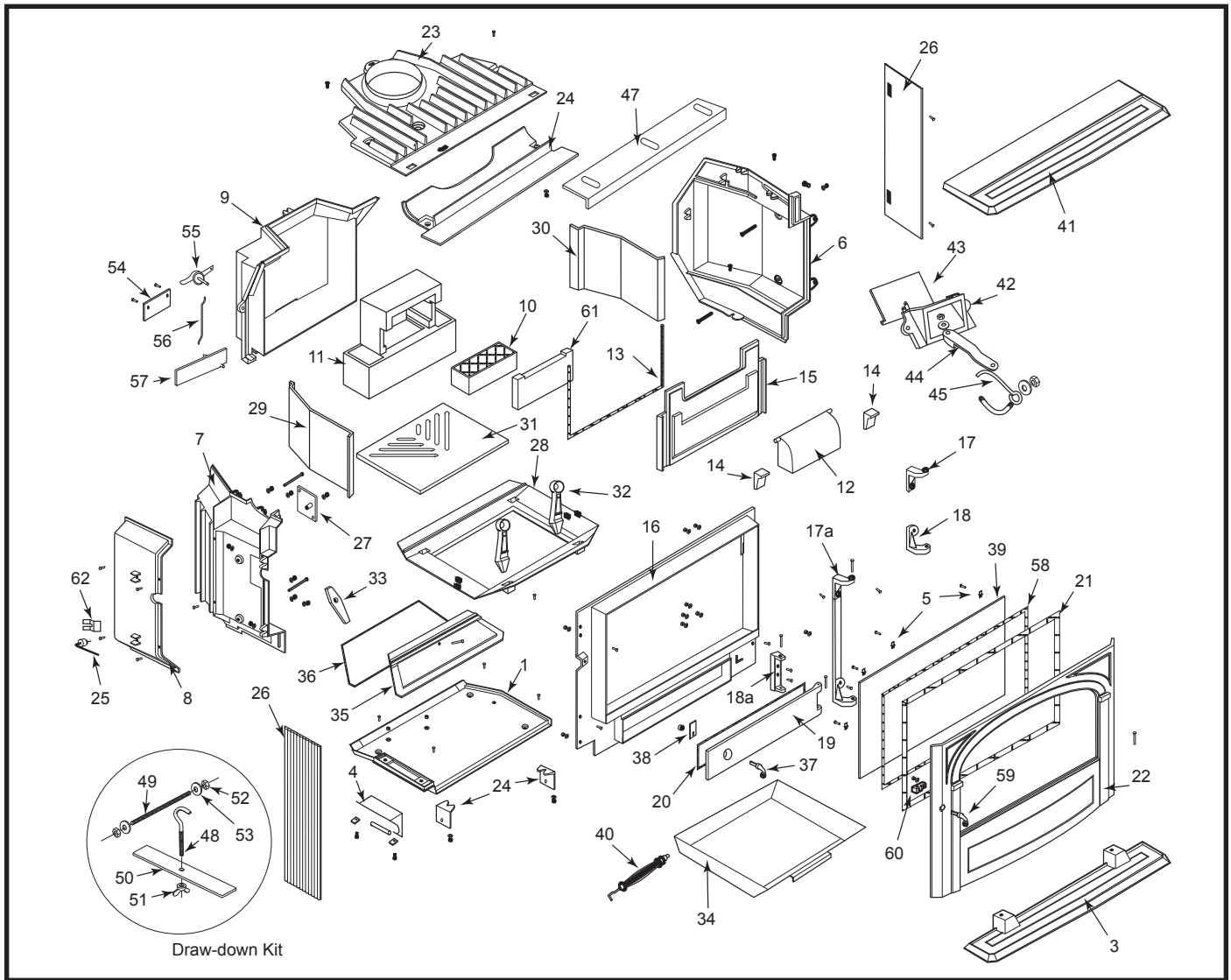

CFM Corporation reserves the right to make changes in design, materials, specifications, prices and discontinue colors and products at any time, without notice.

# WinterWarm Small Insert

## Model 2080

Item Description	Part Number
1. Bottom	1301332
2. Bottom Leg	1301341
3. Shadow Tray	1301321
4. Air Valve, Primary	1601570
5. Clip, Glass	1601396
6. Right Side	1301317
7. Left Side	1301318
8. Primary Air Cover	1301324
9. Back	1301328
10. Catalyst Block	30001153
11. Refractory Assembly	1602527
12. Throat Hood	30001649
13. Fiberglass Gasket	1203588

Item Description	Part Number
14. Wedge	1301340
15. Catalyst Fireback	1301346
16. Front Frame II	1301367
17. Hinge, Upper	1301325
17a. Hinge	1301366
18. Hinge, Lower	1301326
18a. Ashpit Door Hinge	1301336
19. Ashpit Door	1301335
20. Gasket, Fiberglass	1203588
21. Gasket, Fiberglass	1203564
22. Door	See Chart Pg. 22
23. Top	1301307
24. Air Reservoir	1301323

## WinterWarm Small Insert Model 2080 (continued)

Item Description	Part Number
25. Coil & Shaft, Thermostat Assy.	5003733
26. Side Trim Panel	See Chart Pg. 22
27. Thermostat Cover	1301304
28. Gate Frame II	1301357
29. Left Burnplate	1301338
30. Right Burnplate	1301339
31. Grate	1301365
32. Andiron	1301333
33. Retainer	1301301
34. Ashpan	1402442
35. Fan Cover	1301331
36. Gasket, Fan Cover	1203588
37. Steel Handle Stub	30002723
38. Ashdoor Lockplate	1405797
39. Door Glass (19 $\frac{3}{16}$ " x 11 $\frac{3}{8}$ ")	1601571
40. Wood Handle	1600682
Wireform Handle	1600694
Insert, Lifter -Brushed Nickel	30002714
41. Mantel	See Chart Pg. 22
42. Damper Housing	1301348
43. Damper	1301347
44. Damper Handle	1301327
45. Damper Rod Connector	1601573
46. Damper Handle Adjusting Plate	1604507
47. Adjustable Airwash Plate	1405815
48. Hook Bolt	1201497
49. Threaded Rod 1/4-20 x 7 $\frac{1}{2}$ "	1204242
50. Steel Plate 1/4" x 1" x 8"	1405819
51. Wing Nut	1203110
52. Hex Nuts 1/4 20	1203210
53. Washer	1202470
54. Secondary Air Cover Plate	1601492
55. Secondary Air Probe Assy	1601489
56. Secondary Air Link	1601486
57. Secondary Air Flap	1601490
58. Gasket 5/16" Adhesive Backed	1203591
59. Door Handle Assy	30002717
60. Door Handle Pawl Assy	5004025
61. Access Plug	1602516
62. Shield, Primary Air	30002433

Shell Enamel Parts - WinterWarm Small Insert Model 2080			
Part Name	Classic	Sand	Midnight
Door	1301322	1321322	1341322
Side Trim Panel	1301342	1321342	1341342
Mantel	1301320	1321320	1341320

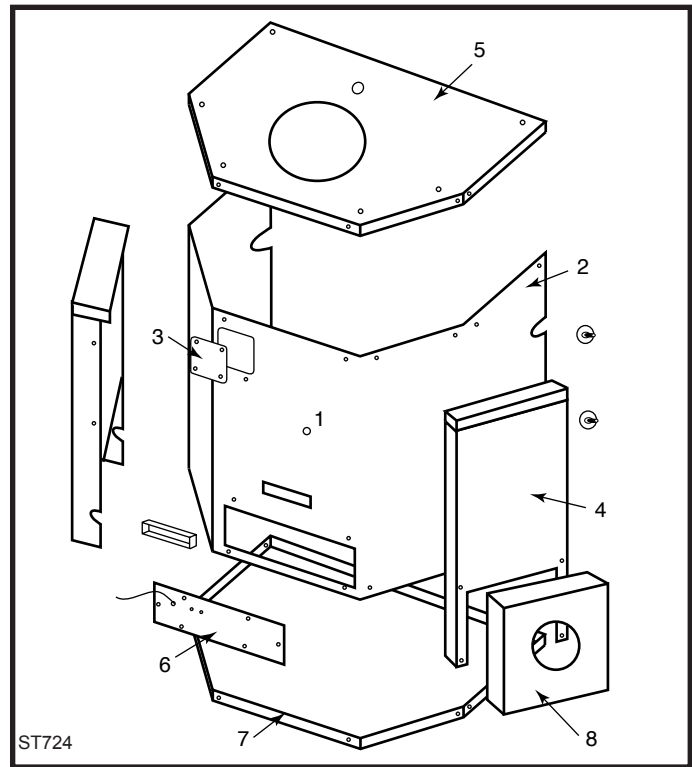

CFM Corporation reserves the right to make changes in design, materials, specifications, prices and discontinue colors and products at any time, without notice.

## Small WinterWarm Cabinet

Item Description	Part Number
1. Access Cover	1405817
2. Shell Backside	1405806
3. Outside Airport Cover	1408730
4. Duct	1405800
Duct Cover	1405799
5. Top Shell	1405805
6. Junction Box Cover Plate	1405802
7. Shell Bottom	1405804
Leveller Bolt	1201744
8. Fan	1601578
Rheostat Handle	1601577
Retainer Clips (1-Rheostat Handle)	1601393
Fan Cable Assembly	5003724
Power Cord	1601482
Terminal Strip	1204897
Fan/Shroud Assembly	5003728
Rheostat Cable Assembly	5003721
Shaker Hole Plug	1600561

For parts and information about your insert, contact your Vermont Castings authorized dealer. For the name of the dealer nearest you, contact:

CFM Corporation  
2695 Meadowvale Blvd.  
Mississauga, Ontario  
Canada L5N 8A3  
800-525-1898

# Warranty

## Limited 3 Year Warranty

CFM Corporation warrants that this woodburning stove will be free of defects in material and workmanship for a period of three years from the date you receive it, except that the catalyst, thermostat assembly, handles, glass door panels, cement, and gasketing shall be warranted as described below.

CFM Corporation will repair or replace, at its option, any part found to be defective upon inspection by a CFM Corporation, Authorized Dealer. The customer must return the defective part or the stove, with shipping prepaid, to the Authorized Dealer or pay for any Authorized Dealer in-home travel fees or service charges for in-home repair work. It is the dealer's option whether the repair work will be done in the customer's home or in the dealer's shop. If, upon inspection, the damage is found to be the fault of the manufacturer, repairs will be authorized at no charge to the customer for parts and/or labor.

Any woodburning stove or part thereof that is repaired or replaced during the limited warranty period will be warranted under the terms of the limited warranty for a period not to exceed the remaining term of the original limited warranty or six (6) months, whichever is longer.

### Limited 1 Year Warranty

The following parts of the woodburning stove are warranted to be free of defects in material and workmanship for a period of one year from the date you receive it: The thermostat assembly, handles, glass door panels, cement, and gasketing. Any of these items found to be defective will be repaired or replaced at no charge, upon the return of the part with postage prepaid to a CFM Corporation Authorized Dealer.

Any part repaired or replaced during the limited warranty period will be warranted under the terms of the limited warranty for a period not to exceed the remaining term of the original limited warranty or six (6) months, whichever is longer.

### Limited Catalyst Warranty

The catalyst will be warranted for a six year period as follows: If the original catalyst or a replacement catalyst proves defective or ceases to maintain 70% of its particulate emission reduction activity (as measured by an approved testing procedure) within 24 months from the date the stove is received, the catalyst itself will be replaced free.

From 25 - 72 months a pro-rated credit will be allowed against a replacement catalyst and the cost of labor necessary for its installation at the time of replacement.

For stove purchases made after June 30, 1990, a third year (25 - 36 months) of no charge replacement will be made when combustor failure is due to thermal degradation of the substrate (crumbling of ceramic material). The customer must pay for any in-home travel fees, service charges, or transportation costs for returning the stove to the Authorized Dealer.

Amount of Time Since Purchase	Credit Towards Replacement Cost
0 - 24 months	100%
25 - 36 months	50 %
37 - 48 months	30%
49 - 60 months	20%
61 - 72 months	10%

Any replacement catalyst will be warranted under the terms of the catalyst warranty for the remaining term of the original warranty. The purchaser must provide the following information in order to receive a replacement catalyst under the terms of this limited warranty:

1. Name, address and telephone number.
2. Proof of original purchase date.
3. Date of failure of catalyst.
4. Any relevant information or circumstances regarding determination of failure.
5. In addition, the owner must return the failed catalyst.

## Exclusions & Limitations

1. This warranty is transferable; however, proof of original retail purchase is required.

2. This warranty does not cover misuse of the stove. Misuse includes overfiring which will result if the stove is used in such a manner as to cause one or more of the plates to glow red. Overfiring can be identified later by warped plates and areas where the paint pigment has burned off. Overfiring in enamel fireplaces is identified by bubbling, cracking, chipping and discoloration of the porcelain enamel finish. CFM Corporation offers no warranty on chipping of enamel surfaces. Inspect your woodburning stove prior to accepting it for any damage to the enamel.

3. This warranty does not cover misuse of the stove as described in the Owner's Guide, nor does it cover an stove which has been modified unless authorized by a CFM Corporation representative in writing. This warranty does not cover damage to the stove caused by burning salt saturated wood, chemically treated wood, or any fuel not recommended in the Owner's Guide.

4. This warranty does not cover a stove repaired by someone other than a CFM Corporation Authorized Dealer.

5. Damage to the unit while in transit is not covered by this warranty but is subject to a claim against the common carrier. Contact Vermont Castings Authorized Dealer from whom you purchased your stove or CFM Corporation if the purchase was direct. (Do not operate the stove as this may negate the ability to process the claim with the carrier.)

6. Claims are not valid where the installation does not conform to local building and fire codes or, in their absence, to the recommendations in our Owner's Guide.

7. The salt air environment of coastal areas, or a high-humidity environment, can be corrosive to the porcelain enamel finish. These conditions can cause rusting of the cast iron beneath the porcelain enamel finish, which will cause the porcelain enamel finish to flake off. This warranty does not cover damage caused by a salt air or high-humidity environment.

8. CFM Corporation shall have no obligation to enhance or update any unit once manufactured.

IN NO EVENT SHALL CFM CORPORATION BE LIABLE FOR INCIDENTAL AND CONSEQUENTIAL DAMAGES. ALL IMPLIED WARRANTIES, INCLUDING THE IMPLIED WARRANTIES OF MERCHANTABILITY AND FITNESS, ARE LIMITED TO THE DURATION OF THIS WRITTEN WARRANTY. THIS WARRANTY SUPERCEDES ALL OTHER ORAL OR WRITTEN WARRANTIES.

Some states do not allow the exclusion or limitations of incidental and consequential damages or limitations on how long an implied warranty lasts, so the above limitations may not apply to you. This warranty gives you specific rights and you may have other rights which vary from state to state.

## How to Obtain Service

If a defect is noted within the warranty period, the customer should contact a Vermont Castings Authorized Dealer or CFM Corporation if the purchase was direct with the following information:

1. Name, address, and telephone number of the purchaser.
2. Date of purchase.
3. Serial number from the label on the back.
4. Nature of the defect or damage.
5. Any relevant information or circumstances, e.g., installation, mode of operation when defect was noted.

A warranty claim will then start in process. CFM Corporation reserves the right to withhold final approval of a warranty claim pending a visual inspection of the defect by authorized representatives.

**CFM Corporation**

---

2695 Meadowvale Blvd. • Mississauga, Ontario, Canada L5N 8A3  
800-668-5323 • [www.cfmcorp.com](http://www.cfmcorp.com)